

**MORSE CODE READER**

**MOHD IKMAL BIN AMRAN**

**51117210299**

**Report Submitted to Fulfill the Partial Requirements  
For the Diploma of Engineering Technology in Telecommunication**

**Universiti Kuala Lumpur**

**British Malaysian Institute**

**NOVEMBER 2012**

**DECLARATION PAGE**

I declare that this report entitle “ Morse Code Reader ” is my original work and all the references have been cited adequately as required by the University.

Signature : .....

Name : .....

Date : .....

**APPROVAL PAGE**

We have examined this report and verify that it meets the program and University requirements for the Diploma of Engineering Technology in Telecommunication.

Date: Day/Month/Year

Signature : .....

Supervisor's Name: .....

Official Stamp : .....

Date: Day/Month/Year

Signature : .....

Co-Supervisor's Name: .....

Official Stamp : .....

## ACKNOWLEDGEMENT

In the name of Allah the Most Graceful and the Most Merciful, I would like to gratefully to Allah S.W.T because of the smoothly progress along to complete this project. Thank you to my project supervisor, Sir SaifulYusri Bin MohdYassin for all the support and help that gave me trustiness to conduct this final year project. I am so glad that everything went well while conducting this project. Perhaps it would be my pleasure to conduct this type of project again one day in the future.

Sometimes I tend to do things on myself because I believe that myself not enough to do everything perfect but I realize that “there are certain things that I might know that others don’t know and the other way”. In this case, I took all the chances related and develop my project based on all the information’s which got through discussions, surfing through internet, books, magazine and as well exchanging information from one other.

I would like to say thanks again to my supervisor and not forgotten to my beloved mother HarisonKasim who supporting me in any condition. This appreciation also I dedicated to my project partner MohdIkmalAmran, the person that gave me a lot of spirit, motivation and ideas along the research and progress of this project. Thanks also to all classmates for giving all the information and cooperation needed. May the kindness and help given would be bless by Allah S.W.T. Thank you

## **ABSTRACT**

This project proposed a morse code reader to listen to morse code by using a tool such as the LCD display, and PIC microcontroller circuit connecting two devices. The main purpose of this project is to create a morse code reader which can read the morse code dots and dashes in a PIC16F84 microcontroller and displayed on the LCD device interface modules. This project involves a combination of hardware such as electronic components, PIC16F84 microcontroller and LCD module which can be generating between input and output signals. Morse code reader is a device that can hear morse code then sends data to the microcontroller and the results will be displayed instantly on the LCD display using serial connection. Morse code signal is triggered as encode and PIC16F84 microcontroller is used to translate and decode morse code as data will be sent directly to the LCD display. This project can be commercialized because it is cheaper to make, easy to used and also the operating program is easy to use.

## TABLE OF CONTENTS

Title page	i
Declaration page	ii
Approval page	iii
Acknowledgement	iv
Abstract	v
Table of contents	vi
List of figures	ix
List of table	xi
References	xii
Appendixes	xiii

### CHAPTER 1: INTRODUCTION

1.1	Introduction	1
1.2	Background project	2
1.2.1	Reasons	3
1.3	Objective	4
1.4	Scope of project	5
1.5	Problems statement	5
1.6	Report organization	6
1.7	Summary	7

### CHAPTER 2: LITERATURE REVIEW

2.1	Introduction	8
2.2	The Development and History of Morse Code	9
2.3	International Morse Code	10
2.4	First commercial use	11
2.4.1	Aviation	11
2.4.2	Amateur Radio	12
2.5	Speed records	12
2.6	The Assistive Technology of Morse Code	13
2.7	Morse Code Applications	14
2.8	Morse Code Reader	15
2.9	Summary	16

### CHAPTER 3: PROJECT METHODOLOGY

3.1	Methodology	17
3.2	Block diagram	18
3.2.1	Operation block diagram	19
3.3	Flow chart based on block diagram	20
3.4	Hardware and Development	21
3.4.1	Transparency	24
3.4.2	Process of etching	26
3.4.3	Drill process	29
3.4.4	Soldering process	30
3.4.5	Recognize project requirements	32
3.5	Software department	38

3.6	Summary	44
-----	---------	----

#### CHAPTER 4: RESULT AND ANALYSIS

4.1	Introduction	45
4.2	Result	47
4.3	Summary	51

#### CHAPTER 5: RECOMMENDATION AND CONCLUSION

5.1	Recommendation	52
5.2	Conclusion	53
5.3	Summary	53

### **LIST OF FIGURES**

Figure 2.0:	Representation of SOS – Morse Code	14
Figure 2.1:	Morse code trainer	15
Figure 3.0:	Block diagram	18
Figure 3.1:	Project flow chart	20
Figure 3.2:	Circuit diagram	21
Figure 3.3:	Component layout in front	23
Figure 3.4:	Morse code reader layout	25
Figure 3.5:	Print circuit to the UV board	26
Figure 3.6:	Process take out the green layer	26
Figure 3.7:	Process automatically to take out the copper that unused	27



Figure 3.8: Process manually to take out the copper that unused	27
Figure 3.9: Process to take out the green layer and leave the copper	28
Figure 3.10: Process of drill PCB	29
Figure 3.11: The final construction component on the board	31
Figure 3.12: The component construction in front board	31
Figure 3.13: Chip pin out for PIC16F84	33
Figure 3.14: The figure show the PIC16F84	34
Figure 3.15: Chip pin out for LM358	37
Figure 3.16: Flow of software	38
Figure 3.17: Read the PIC program process	39
Figure 3.18: Erasing program process	40
Figure 3.19: Program that install into PIC16F84	41
Figure 3.20: Writing program process	42
Figure 3.21: Verification process	43
Figure 4.0: LCD screen in 2-line	47
Figure 4.1: Testing the circuit	48
Figure 4.2: Using 9V battery as a source	48
Figure 4.3: Troubleshoot process	49
Figure 4.4: Result	49
Figure 4.5: Morse code reader and Morse code trainer	50

## LIST OF TABLE

Table 3.0: LCD 16X2 pin out arrangement

36

## REFERENCES

1. Owen Bishop (2009) "Electronics Circuit and Systems", Third Edition, 376 pages, an imprint of Elsevier.
2. Ian Sinclair and John Dunton (2003), "Practical Electronics Handbook", Sixth Edition, 570 pages, Newnes.
3. Steve Ford WB81MY (2010), "Remote Operating for Amateur Radio", A.R.R.L.
4. Roger Cooke, G3LDI (2010), "Morse Code for Amateur Radio", 32 pages, ISBN 9781 9050 8658 0
5. Deepak Gupta, "Electronics And Telecommunication Engineering", G.K. Publications
6. Andrew Leven, "Telecommunication Circuits and Technology", Newnes, Array ISBN
7. <http://www.enchantedlearning.com/morsecode/notopad.shtml>
8. PIC16F84 data sheet  
<http://freedatasheets.com/downloads/Enhanced%20FLASH%20%20EEPROM.pdf>

## **CHAPTER 1**

### **INTRODUCTION**

#### **1.1 INTRODUCTION**

Chapter one is an introduction of the entire of the project. They are including with importance of this project and motivation of the projects. Besides, the introduction, problem statement, objective and scope of project are discussed in this chapter.

## 1.2 BACKGROUND PROJECT

Morse code is an alphabetic code of long and short sounds, originally transmitted by telegraph. Each letter in the alphabet has a corresponding sound or series of sounds unique to it. The long sounds are referred to as dashes, while the short sounds are dots. Varying lengths of silence denote spaces between letters or words.

To make a dot on a telegraph, the telegraph key or switch was depressed and allowed to rapidly spring back. To make a dash the key was held down longer before allowing it to rebound. Thus messages were sent by tapping the key in a rhythm of coded letters. Messages were received via a radio transceiver, sounding like dots and dashes of static.

However, to read morse code that is considered secret is not as easy as one thinks, especially to those who are not skilled in reading morse code. So this final year project is to study about the morse code and to develop Morse code reader that can read and translate morse code to text. Then watch Morse code signals turn into solid text messages as they scroll across an LCD display. No cables to hook-up, no computer, no interface, no other equipment needed. The project implementations go through the following process:

1. Choose the microcontroller and programming.
2. Design and developed a Morse code reader as a receiver and using software in the PC as a transmitter.

### 1.2.1 Reasons

#### **Customer's needs**

Our clients are military. Analyze that they want some solutions for solving quickness problems identifying the kind of help needed by their members who require emergency aid. So, when they use our project can ensure that all their members or the public who need help will respond very well to service their proficiency.

#### **Target specifications**

Army is the target. Plans for this project as a privilege for the military to facilitate their work. Morse code reader is detailed in reading Morse code for the translate into words. For example, the most well known Morse code phrase is SOS (save our souls). SOS was chosen because the code for it -- 3 dots followed by 3 dashes followed by 3 dots -- is unmistakable as anything else and recognizable even to those who do not know Morse code. Thus, it is very helpful in identifying and accelerating military assistance without the need of skilled workers for reciting morse code.

#### **Generate Design Concept**

Our Morse code reader produced in various sizes, until to the small size of the pocket so that it is more easily carried by soldiers in every mission without requiring much space. We also use the concept of manual means using handcrafted to progress this project. Handmade is better quality using machine because when by ourselves, it's more creative, be careful, have good grades, and safety for use. Compare to use the machine, it causes more errors and inaccurate results.

### **1.3 OBJECTIVE**

1. To investigate the characteristics of Morse Code Reader that can listens the audio beeps and identifies dots and dashes.
2. To developed a prototype of Morse Code Reader that can listens to Morse code through microphone and translates it to text.
3. Using Programmable Interface Controller (PIC) as its main controller.
4. To understand the function of Liquid Crystal Display (LCD) as a data presented.

By using our Morse code reader, the application can read the data of dots and dashes accurately and quickly and then translate each message in the text. Automatically translated reading will be displayed on the Liquid Crystal Display (LCD) screen. It is much easier than the old method of manually.

The project also facilitate rescue work and provide emergency assistance by the military. Saves time military personnel in identifying each message received just by reading the messages that have been translated and displayed on the LCD screen morse code reader. Thus every member of the military can read morse code without waiting for skilled people to translate.

Finally, our morse code reader is simple to use and very user friendly when it its only use 9V battery as power supply. It uses a PIC where it has been programmed to identify each letter representing the dot and dash includes identifying sound using the audio input (internal microphone).

## **1.4 SCOPE OF PROJECT**

This Morse code reader is a combination of hardware and software. Both are very important to determine whether the Morse code reader can function properly and as desired. Below are the scopes of the work for hardware used in this project:

1. PIC 16F44-4 circuit for microcontroller
2. LCD display module

## **1.5 PROBLEM STATEMENTS**

Most of the recent electronics product is using high voltage and complex devices. Normally, computer is used to display device as the display device to display the data that listens from microphone.

The problem occurs because of the used of PIC microcontroller that need software to be installed. The problem is when we just have the program in HEX file, so we can't modified or rectify any mistakes in that file. The second problem is, in this project we just use 9V power supply as necessary but their voltage not sufficient and no current that reaches the microphone. Thus this problem, causing the microphone cannot function.



## 1.6 REPORT ORGANIZATION

This report consists of five chapters what describes in detail and clearly about this project. They are :

- 1) Introduction
- 2) Literature Review
- 3) Project Methodology
- 4) Result and Analysis
- 5) Recommendation and Conclusion

Chapter one is an introduction of the entire of the project. They are including with importance of this project and motivation of the project. Besides, the introduction, problem statement objective and scope of project are discussed in this chapter.

Chapter two will discuss the study and all the information that are related to this project. Rest of the chapter will discuss the literature review about this project. In this chapter all the theories and concepts that is relevant and will be use in doing this project is shown in detail.

Chapter three will be explaining the methodology of implemented in this project in detail. In this project methodology, it includes research of LCD Display, PIC Microcontroller and all the main components. Other than that, the methods and the project flow have been explained in clearly.

The result and analysis are obtained on this project are given in chapter four. In this chapter, the progress of the project was explained. This chapter will include theoretical findings, conceptual and simulations results.

Last chapter in this thesis, which include the project and some suggestion are given.

## **1.7 SUMMARY**

This project is to developed a Morse code reader and to prove the voice is that it can reach long distance with very low power due to the fact that only the carrier is transmitted. A Morse code reader is used to listens morse code audio and translates it to text by identifies dots and dashes.

## **CHAPTER 2**

### **LITERATURE REVIEW**

#### **2.1 INTRODUCTION**

Chapter two will discuss the study and all the information that are related to our project. Rest of this chapter will discuss the literature review about this project. In the literature review, it includes technology and morse code applications. In this chapter the theory and concept that is relevant and will be use in doing the project is shown in detail.

## **2.2 THE DEVELOPMENT & HISTORY OF MORSE CODE**

Samuel F.B. Morse was born in Massachusetts in 1791. He was a professor of arts and design, a professional painter, and the founder of the Royal Academy. Inspired by a discussion he had in 1832 during a return trip by sea back to America, Morse began work on electromagnets. He partnered with Professor Leonard Gail and Alfred Vail and together they rigorously worked on building the telegraph. Dubbed the Morse code, an U.S. patent was received in 1854 from the Supreme Court.

The Morse code was created using the letters of the alphabet and ten numerals, which were represented by long and short pulses. Each character, including letters, numerals, and punctuation was represented by a given pattern of code. As one operator sent a message using these long and short pulses, another well-trained operator using a telegraph key would translate the message at the receiving end. In this way, the telegraph using the Morse code system electronically sent a message.

The first Morse code to be sent and received was from the U.S. Capitol's chamber of the Supreme Court to the railway depot in Baltimore on May 24, 1844. It simply stated, 'What hath God wrought?' It originally used a paper system that produced dashes and dots, but later used sound. Because Morse code was easy to understand and its efficiency even with wiring of low quality, it soon became popular. It was the standard both in European countries as well as in the United States. Its only real drawback was that there were sometimes errors due to the use of characters in place of spaced dots. This was especially a problem when transmission was used over undersea cables. The Morse code was a long-lived system that was used professionally for over 160 years.

## **2.3 INTERNATIONAL MORSE CODE**

Morse code has been in use for more than 160 years, longer than any other electrical coding system. What is called Morse code today is actually somewhat different from what was originally developed by Vail and Morse. The Modern International Morse code, or continental code, was created by Friedrich Clemens Gerke in 1848 and initially used for telegraphy between Hamburg and Cuxhaven in Germany. Gerke changed nearly half of the alphabet and all of the numerals resulting substantially in the modern form of the code.

After some minor changes, International Morse Code was standardized at the International Telegraphy Congress in 1865 in Paris, and was later made the standard by the International Telecommunication Union (ITU). Morse's original code specification, largely limited to use in the United States and Canada, became known as American Morse code or railroad code. American Morse code is now seldom used except in historical re-enactments.

A new code had been generated by 1851. It was referred to as the continental or international code. It was a modified version of the Morse code, which eliminated the characters for spaced dots. All telegraph systems replaced their systems to accept the new code, except North America, which kept the original Morse code. Unlike the Morse code of the past that used a single wire to transmit each character, later telegraphs sent each letter through a different wire.

## **2.4 FIRST COMMERCIAL USE**

### **2.4.1 Aviation**

For years, Morse code was a vital part of international aviation for both military and commercial pilots. It was a requirement for pilots to be familiar with the code. It was regularly used to identify navigational beacons that continually transmitted three letter identifications in code, as well as for communications systems. In fact, aeronautical charts continued to use three-letter Morse identification codes for each of the airports well into the 1990s. Today sectional charts for NDB and Vortac still show the Morse signals used for navigation.

In aviation, instrument pilots use radio navigation aids. To ensure that the stations the pilots are using are serviceable, the stations all transmit a short set of identification letters (usually a two-to-five-letter version of the station name) in Morse code. Station identification letters are shown on air navigation charts. For example, the VOR based at Manchester Airport in England is abbreviated as "MCT", and MCT in Morse code is transmitted on its radio frequency. In some countries, if a VOR station begins malfunctioning it broadcasts "TST" (for "TEST"), which tells pilots and navigators that the station is unreliable. In Canada, the identification is removed entirely to signify the navigation aid is not to be used.

## **2.4.2 Amateur Radio**

Morse code is currently most popular with those involved in amateur radio. Radio jargon for Morse code is “CW” due to the fact that a continuous wave is switched off and on with short and long elements using the Morse code characters. It is a kind of character encoding that takes the telegraphic information and transmits it using rhythm. Once required in order to receive an amateur radio license, Morse code proficiency tests were discontinued in 2006. This however, did not curtail the strong interest of amateur radio users who continue its regular use today, usually preferring the Farnsworth method. CW allows users to transmit very detailed information not easily transmitted in other forms of communication and at a greater rate of speed.

## **2.5 SPEED RECORDS**

Over time, regular Morse code operators become very proficient and are able to decipher code quickly in their heads. Some have been tested at more than forty words per minute (WPM). International code contests were held regularly to test an operator’s skills and some are still held occasionally today. Ted R. McElroy set the all-time official speed record in 1939 in a contest held in Asheville, NC by copying 75.2 WPM. It is possible that the record has been broken unofficially though, as it is thought that some operators may be so proficient as to decipher 100 WPM.

Harry Turner accomplished the fastest message ever sent in 1942. During a demonstration at a military base, he reached 35 WPM. Current amateur radio societies continue to recognize operators today and have recorded speeds up to 60 WPM.

Although these speeds seem smaller, there have been differences in judging speed over the years. It is dependent on the 5-dot versus the 7-dot and the 50-dot versus the 60-dot durations and other formats of judging.

## **2.6 THE ASSISTIVE TECHNOLOGY OF THE MORSE CODE**

Morse code can also be employed for those with disabilities. Communication is often difficult for some disabled people and the use of Morse code has helped many. It has also spawned creative abbreviations of the code. An example of that is the barcode created by Norman Woodland, who extended the dashes and dots downward and changed the widths of the lines. Code can be sent by anyone, even those with minimal motor control. Originally, a caretaker would have to learn how to decode using a specially marked typewriter. Later there were voice typewriters that used Votem or Morse.

Today Morse code can be translated via Morse code reader or computer as an aid in communicating with speech. Sometimes this is accomplished using a tube in which the user sucks or blows in order to create the right code. It is most advantageous due to the fact that once Morse code is learned it doesn't require a display in order to use. Those with almost any disability, including those with severe motion issues, can use it. Even those with sensory disabilities are aided by using a buzzer applied to the skin.



## 2.7 MORSE CODE APPLICATIONS

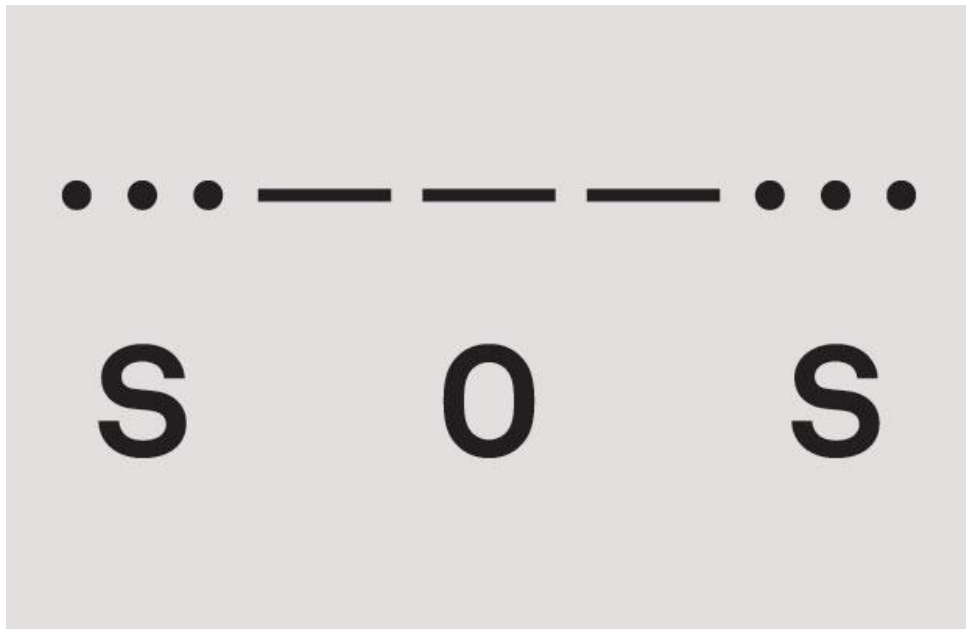

**Figure 2.0** :Representation of SOS - Morse code

The Morse code for SOS is a standard for those who need help. Using the 3-dot, 3-dash, 3-dot signal is an all-important application of the code. Sending methods include flashing a mirror or other shiny object like a flashlight, using the CW method on a radio by toggling on and off, tapping out the signal or using other similar methods.

## 2.8 MORSE CODE READER

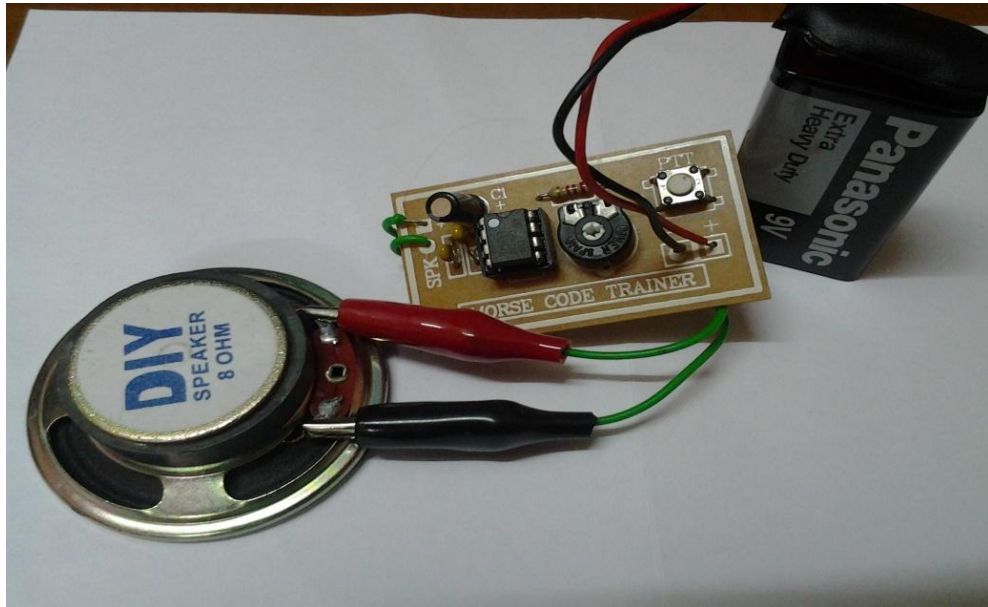

**Figure 2.1 :** Morse code trainer

We came out with the project that can read Morse code namely, Morse code reader. Our Morse code reader is a project created to receive telegraph. Morse code reader can listen the morse code standard sequence elements of short and long to represent letters, numbers, punctuation marks and special characters message via microphone. Morse code sent in the form of short and long elements that formed by sounds, marks or pulses, and known as "dots" and "dashes" or "DIT" and "DAH". Then the Morse codereader will translate morse code that listened through the microphone in a text, then displayed it on the LCD screen.

Actually, our Morse code reader act as receiver and Morse code trainer (See Figure 2) is a transmitter part. Morse code trainer will produce morse code sound, then it will be listens by microphone and PIC microcontroller will

decoded then translate it to text without the need for a skilled translator to listen to morse code. Thus helping to translate morse code more faster and accurately. This demonstrates a system which can automatically recognize Morse code and turn it back into characters, displayed on the LCD.

## **2.9 SUMMARY**

This literature review is a body of text that aims to review the critical points of element in the making of Morse code reader. All the theories, applications, technology and studies were briefly describe in this chapter.

Other than that, for the transmitter and receiver part as the important components used in this project like encoder and decoder were explain in this chapter. Lastly, this chapter can be best describe as the reference to people explore this theories and idea to accomplish the mission for doing this Morse code reader.

## **CHAPTER 3**

### **PROJECT METHODOLOGY**

#### **3.1 METHODOLOGY**

This project is a breakthrough in technology, which is used by army or secret agents like spy, they use a secret code that use ' .' (DIT) And ' - ' (DAH) only, with this code the enemy will be difficult to identify an emergency signal or a message. This project gives us to better understand the morse code more easily. This information project can get through the internet resources, through the electronics magazine and other new resources that related to this project. For our final year project Morse Code Reader we refer through the magazine that our university give. From the information given the project have been studying and upgraded by ourselves to make sure the time thinking reaction circuit is made by ourselves and understand about the constructional project and the goodness of the product.

### 3.2 BLOCK DIAGRAM

The basic block diagram below show the Morse Code Reader as the circuit receiver and change the morse code sound .

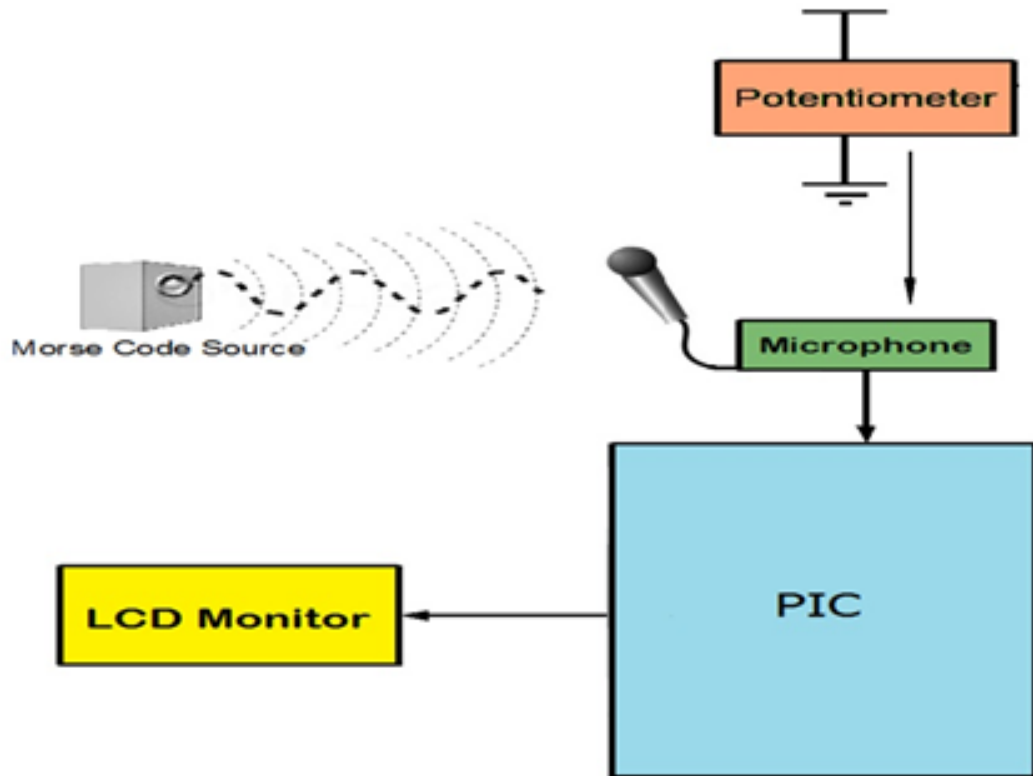

Figure 3.0 : Block diagram

### 3.2.1 Operation block diagram

In this project we used PIC16F84-4 for translate the morse signals to word this project. Firstly we have the Morse Code Source. The Morse code Source is used for to sent the input ' morse signals' .The Morse Code Source is not connected to the circuit its because the Morse Code Source use just only to sent the morsesignals. The microphone its put near the Morse Code Source .So if the any morse signal from the Morse Code Source the Microphone will detect and the signal and the signal will transmute to the PIC. The main function of the PIC is to convert or translate the output voltage signal of the microphone, from analogue to digital. We need to convert the signal because we want to get the input for the LCD display .For the PIC, we has use the PICKit 2 v2.55 to program.

Other than that , using laptop can additionally be use to output Morse Code to the hand-held unit, for display on its screen or monitoring as an audio signal. There are several modes of code output from the laptop . translation of a text file to morse direct keying of alphanumeric characters for immediate translation to morse , use of keyboard as a morse key with the duration of keypresses simulating morse dots and dashes .

**3.3 FLOW CHART BASED ON BLOCK DIAGRAM**

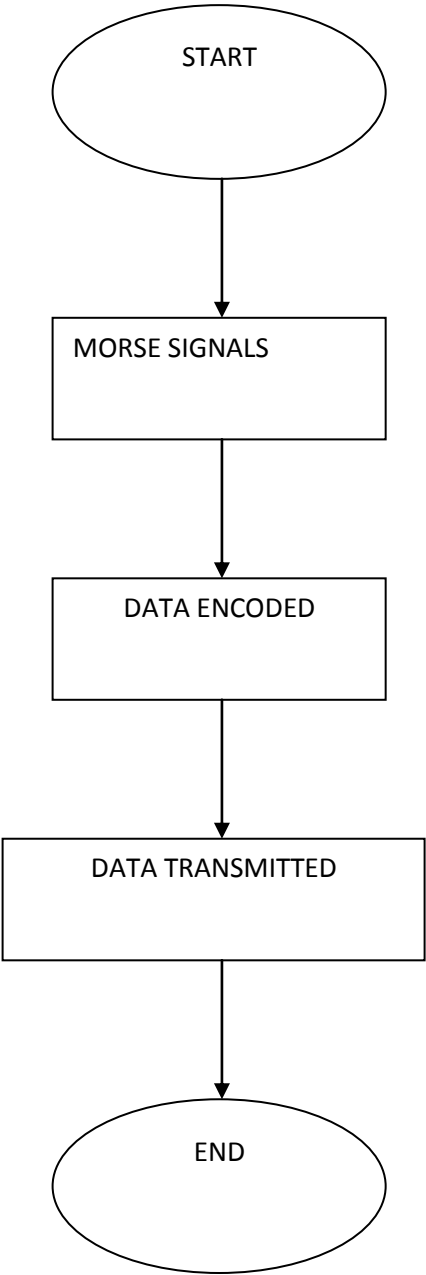

**Figure 3.1** :Project flow chart

### 3.4 HARDWARE AND DEVELOPMENT

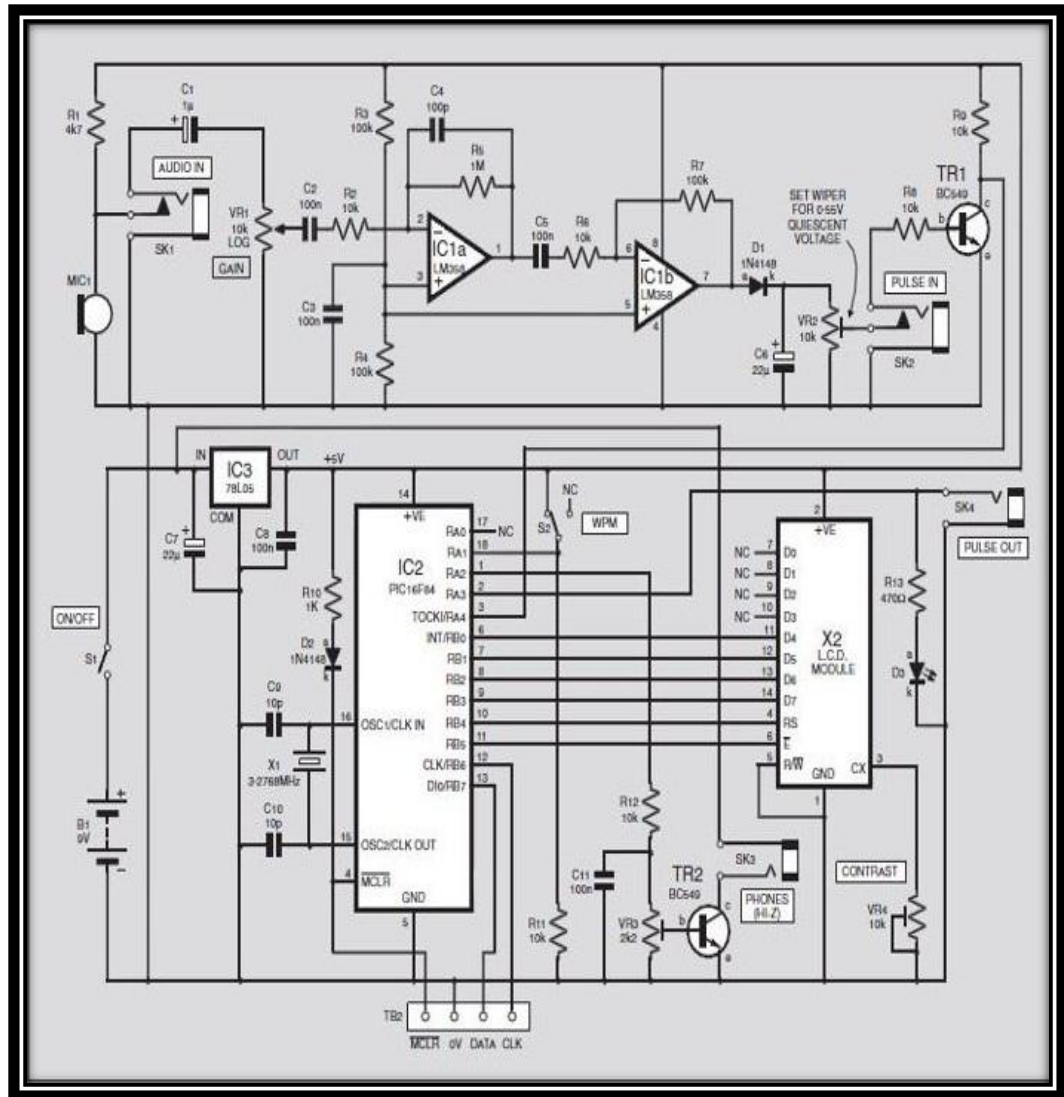
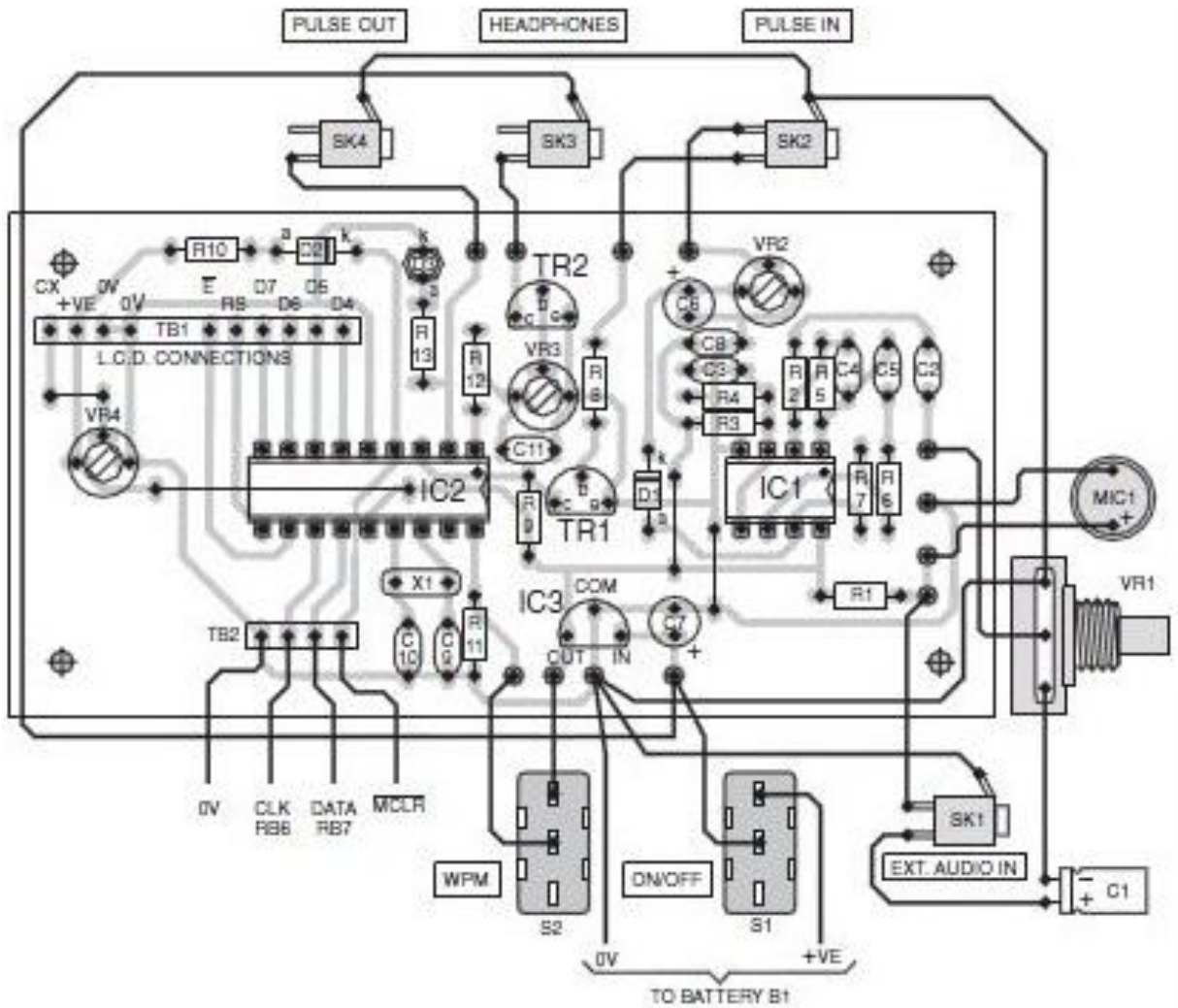

Figure 3.2 :Circuit diagram



This schematic including the heart of the system, PIC16F84-4, that need to be programmed, LCD 2 line, 16 character per line that display the result morse code in word, switch, l.e.d.s, diode, zener diode, capacitors and resistor.

Base the schematic diagram above (Figure 3.2) other construction will be made. The circuit board has designed to printed circuit board component layout and full-size underside copper foil master pattern. The Morse Code Reader printed board circuit is shown as above.

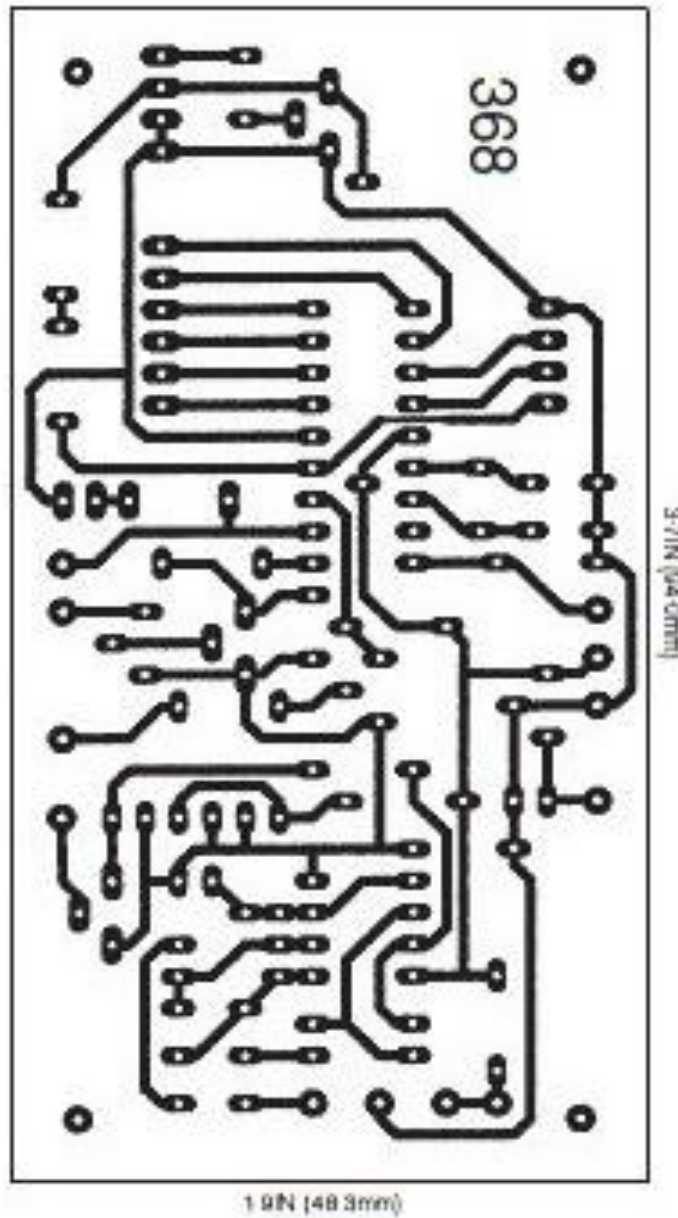

**Figure 3.3 :**Component Layout at infront

The figure below shows the printed board component at the back.

### 3.4.1 Transparency

After construct all the circuit used in this thesis by using Ares PCB layout software, the circuits were print out. A finished design should look like a graphical representation of the traces that should reside on the finished board. The image must be mirrored because of the way we are going to use it later in the process. Once the layout design is ready for production, the entire layout should be able to print a mirrored image of it using 1: 1 scale. Printing by using Laser Jet printer is the best solution because the Toner, which is the black substance (laser ink) used for laser printing is actually a polymer that does not soak into the paper like real ink. The toner is heated inside the printer and when it melts it sticks to the surface of the glossy paper. The paper that suitable to print out all this circuits is glossy paper or plain white plastic paper. When the plain white plastic already printed with the layout, the next process is ironing or using UV Exposure Unit.



**Figure 3.4** :Morse code reader layout

From the component layout above most of the Morse Code Reader component construction are mounted on a small single-side printed circuit board and the topside component layout together with a full size underside copper foil master as shown in the above.

**3.4.2 Process of etching**



**Figure 3.5 : Print circuit to the UV board**

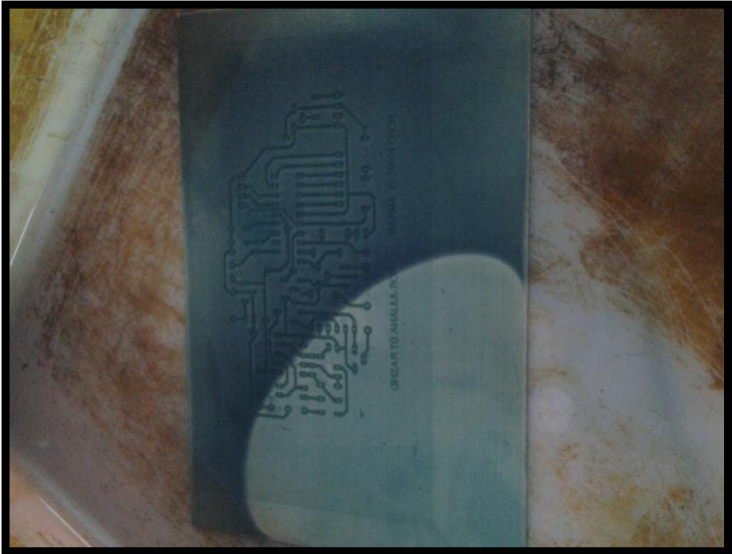

**Figure 3.6 : Process take out the green layer**



**Figure 3.7 :** Process automatically to take out the copper that un use



**Figure 3.8 :** Process manually to take out the copper that un use



In this process, etching will be done by using Ferric Chloride powder. Put around 2 -3 spoon of Ferric Chloride powder into the plastic container. Too little Ferric Chloride would slow the etching process. Too much will result in a messy dark mud like fluid. Then pour some hot water and stir until in the powder dissolved in the hot water. After that. Put the PCB that have been carbonized into the container. Then start to shake and make sure the Ferric Chloride does not come out from container. This session need about 5 to 15 minutes depends on the PCB size. After finish the etching process, make sure the circuitry without the carbon has been etched or not. If not, the process needs to be done one time again until all the parts that do not have carbon been etch. Lastly, confirm all the parts without carbon been etch, the PCB should be washed under running water to remove any leftover of the etching fluid and stop the etching process.



**Figure 3.9 :** Process to take out the green layer and leave the copper

### 3.4.3 Drill process

After cleaning the PCB with clean water, rinse it using tissues and then by using high speed mini drill bits size 1.0mm drill the components pad. Before that make sure there is a board to cover the surface for drilling the PCB. All component holes at the circuit layout should be drill using the suitable size of drill bit based on the component type. After finished the drills all holes, cleans up the PCB using thinner. Clean up the photocopy carbon before soldering process.

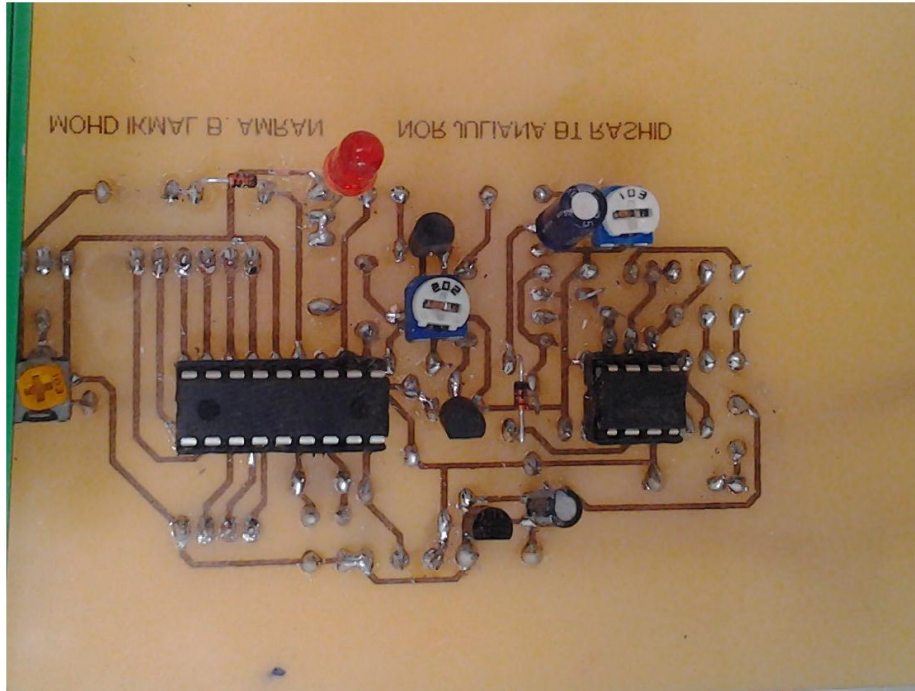

**Figure 3.10** : Process of drill PCB



#### **3.4.4 Soldering process**

After cleaning the PCB, the next step is soldering the components on the board. First of all, the components such as the resistor need to be bend the leg of the resistor by using long nose pliers by measuring the components pad to get the actual size to be bend. After that the leg of the components will be put into the right position of holes that have been drill and then start soldering the components. If there is problem during soldering it, place a plastic tape on the components to the PCB at the side of the PCB to make sure the components not fall during soldering. For the components on board, when soldering it need to solder a bit faster to make sure the components will not damage during soldering process because of overheating. After finish soldering, the PCB need to check once again the connectivity before apply voltage on the circuitry. This safety need to be follow unless the components will easily burn out because of the shortage at the grounding circuitry.



**Figure 3.11** : The final construction component on the board

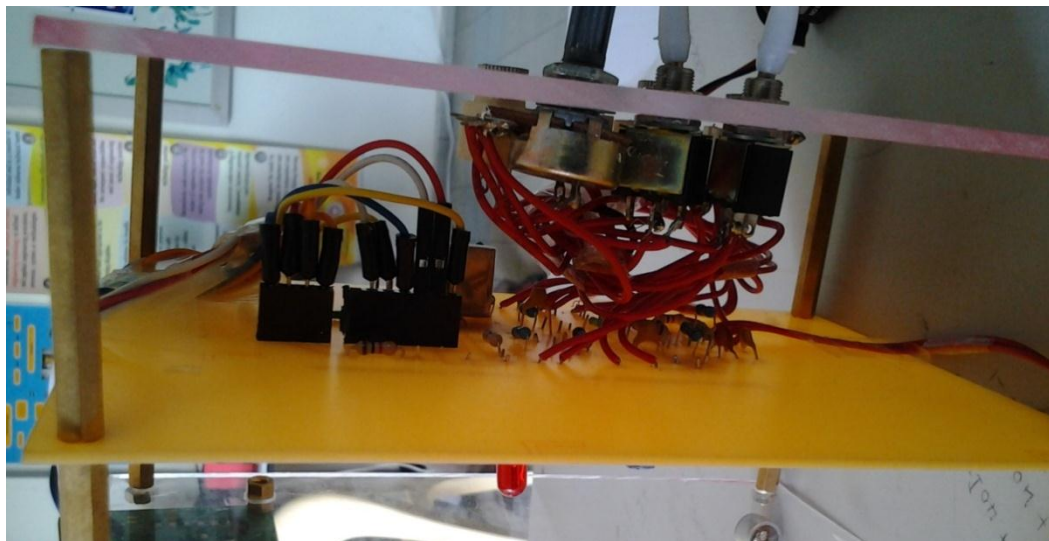

**Figure 3.12** : The component construction in front board

### **3.4.5 Recognize project requirements**

L.C.D display can be housed directly on the p.c.b as can the l.e.d.s, although this was not done with the prototype. Begin construction by drill necessary holes for every component and then begin by fitting the d.i.l sockets required for IC1 and IC2, fit the resistor followed the transistor, capacitor C1 and C2, the L.E.D.s, switch and finally connect colour-coded wires for the battery pack and fit the L.C.D display at the upper side. Finally, the circuit can be tested with connected it to the power supplies

The inputs and outputs of this project construction are the “Morse” signals from laptop and received by microphone as the sensor .The PIC 16F84 microcontroller will translate the morse signals. Microphone is the miniature electrets type which receives its power from resistor R1 and allow the unit to be placed near the speaker of the laptop Morse signals without any physical connection to it . Socket SK1 enables direct connection to laptop and the microphone os automatically disconnected in this instance . The values oh capacitors C2 and C4 respectively give a bit of bass and treble cut to the audio frequency being received, helping to reduce although not totally eliminate false triggering by any out of band noise on the signal.

1) **PIC 16F84-4**

This PIC 16F84-4 is the heart of the system. This is one of the more recent PICs and has built in oscillator, is flash reprogrammable, and available for a remarkably low price. This programmable can be modified for the project requirements. These hex files are available for free on the EPE site.

**Pin diagram :**

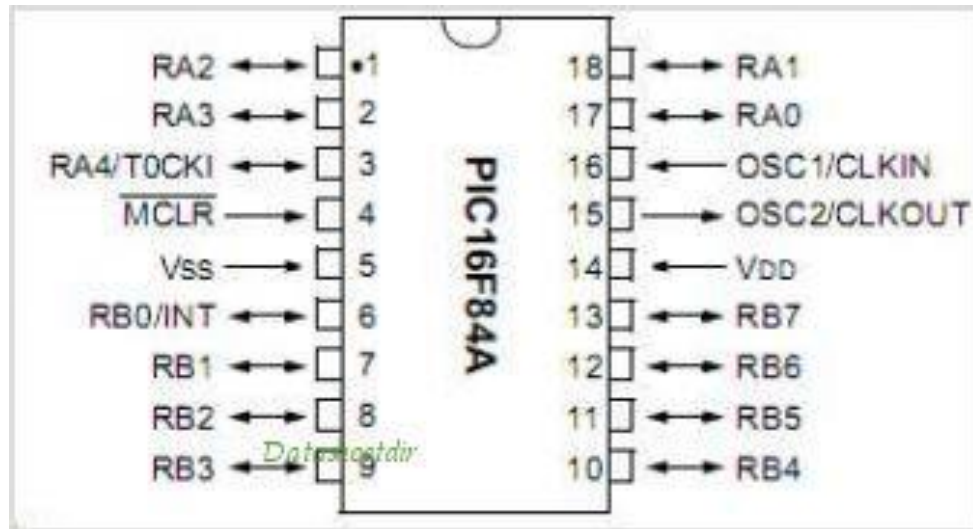

**Figure 3.13 :** Chip pin out for PIC16F84

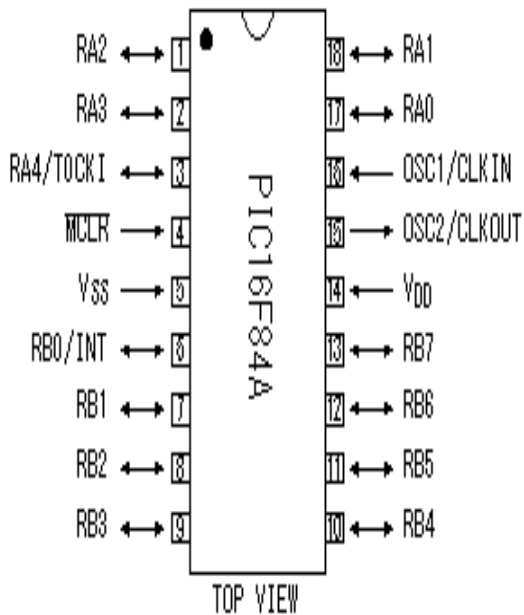

OSC1/CLKIN : Oscillator crystal input.  
External clock source input.

OSC2/CLKOUT : Oscillator crystal output.  
Connects to crystal or resonator in crystal oscillator mode.

MCLR(inv) : Master clear(reset)input.  
Programming voltage input.  
This pin is an active low reset to the device.

RA0 - RA3 : Bi-directional I/O port.

RA4/T0CKI : Bi-directional I/O port.  
Clock input to the TMR0 timer/counter.

RB0/INT : Bi-directional I/O port.  
External interrupt pin.

RB1 - RB7 : Bi-directional I/O port.

$V_{SS}$  : Ground

$V_{DD}$  : Positive supply(+2.0V to +5.5V)

**Figure 3.14** :The figure show the PIC 16F84 .

The figure above is revision on LCD 16×2 construction with the other component that related to the morse code reader construction.

## 2) **L.C.D 16x2**

LCD (Liquid Crystal Display) screen is an electronic display module and find a wide range of applications. A 16x2 LCD display is very basic module and is very commonly used in various devices and circuits. These modules are preferred over seven segments and other multi segment LEDs. The reasons being: LCDs are economical; easily programmable; have no limitation of displaying special & even custom characters unlike in seven segments , animations and so on . A **16x2 LCD** means it can display 16 characters per line and there are 2 such lines. In this LCD each character is displayed in 5x7 pixel matrix. This LCD has two registers, namely, Command and Data.

The command register stores the command instructions given to the LCD. A command is an instruction given to LCD to do a predefined task like initializing it, clearing its screen, setting the cursor position, controlling display etc. The data register stores the data to be displayed on the LCD. The data is the ASCII value of the character to be displayed on the LCD. Click to learn more about internal structure of a LCD.

### The Pin Diagram :

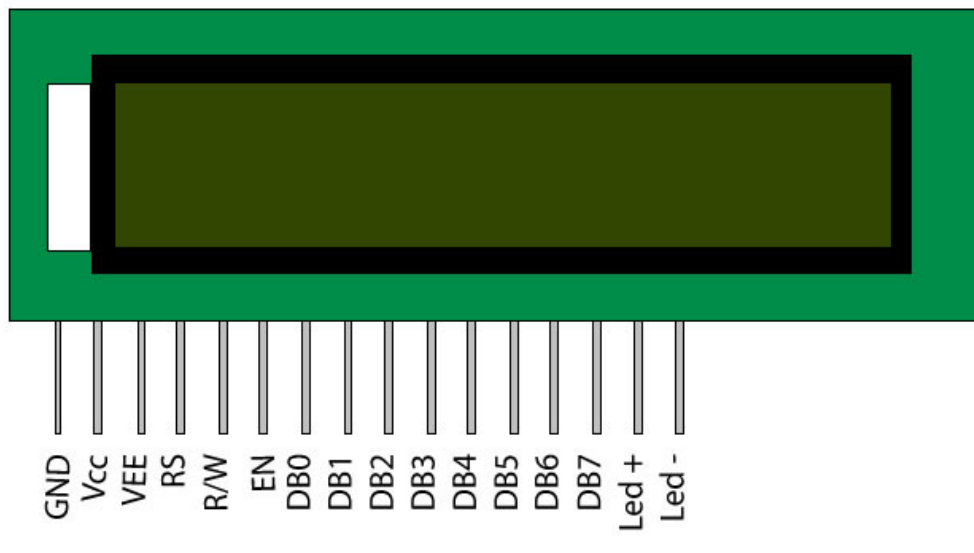

### Pin Description :

Pin No	Function	Name
1	Ground (0V)	Ground
2	Supply voltage; 5V (4.7V – 5.3V)	Vcc
3	Contrast adjustment; through a variable resistor	VEE
4	Selects command register when low; and data register when high	Register Select
5	Low to write to the register; High to read from the register	Read/write
6	Sends data to data pins when a high to low pulse is given	Enable
7	8-bit data pins	DB0
8		DB1
9		DB2
10		DB3
11		DB4
12		DB5
13		DB6
14		DB7
15	Backlight VCC (5V)	Led+
16	Backlight Ground (0V)	Led-

**Table 3.0 :** LCD 16X2 pin out arrangement

### 3) LM358 dual op-amp

The LM358IC is a specialized part very popular among electronics enthusiasts. It is cheap and easy to obtain from specialized stores. The LM358 op amp is a dual op amp IC that is designed to run from a single supply. Op amps were originally designed to run from split rails ie: +5V and -5V. With the popularity of digital electronics, single supply circuits became very common, and it is now much more convenient to run circuits off of a single supply like +3.3V. If only a single supply is available, this is a good op amp choice for prototyping or designing the system. This IC can accept supply voltages from 3V to 30V .

**Pin Diagram :**

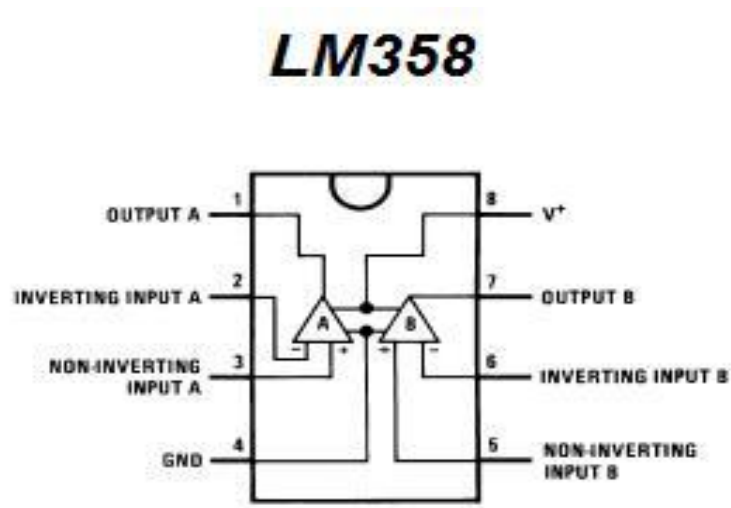
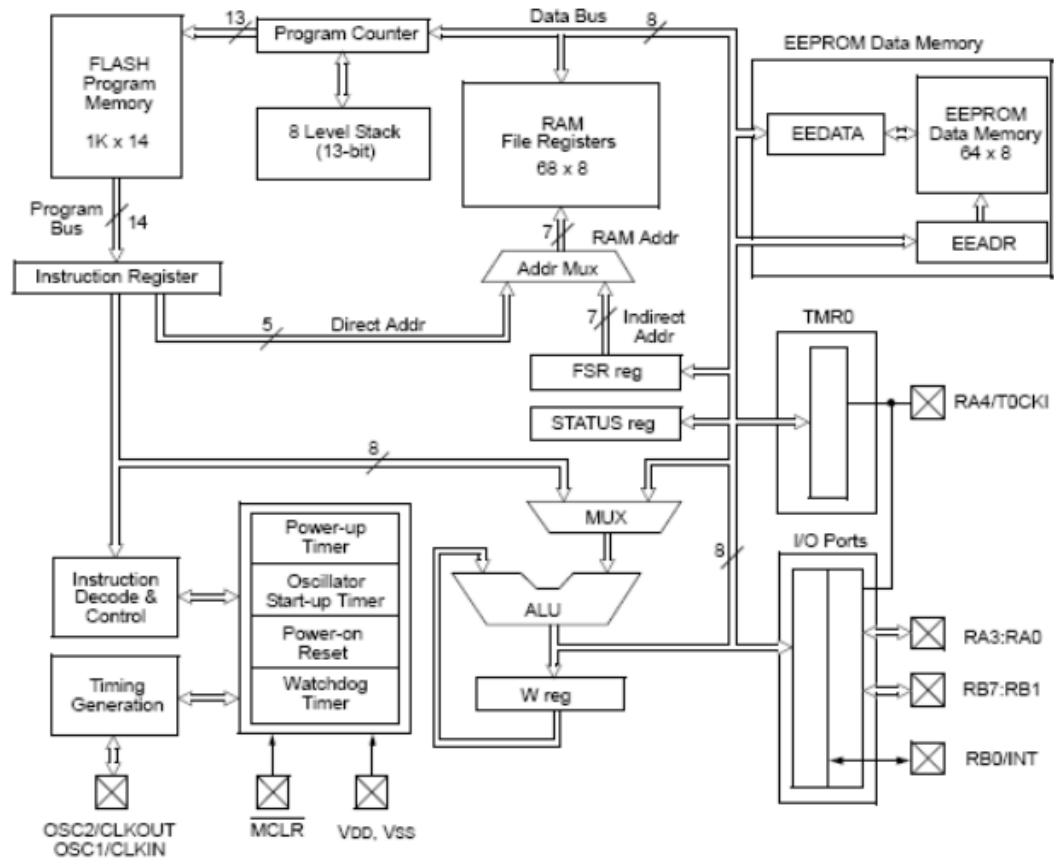

**Figure 3.15 :**Chip pin out for LM358



### 3.5 SOFTWARE DEPARTMENT

As this project use a PIC that heart of the system .The PIC is will the program with hex that we have to download for the EPE site .



**Figure 3.16** :Flow of software

For this project program we use HEX code, user guide with PICKit™ User's Guide. This PICKit™ is suitable with the requirements of this project.

### Microcontroller programming concept

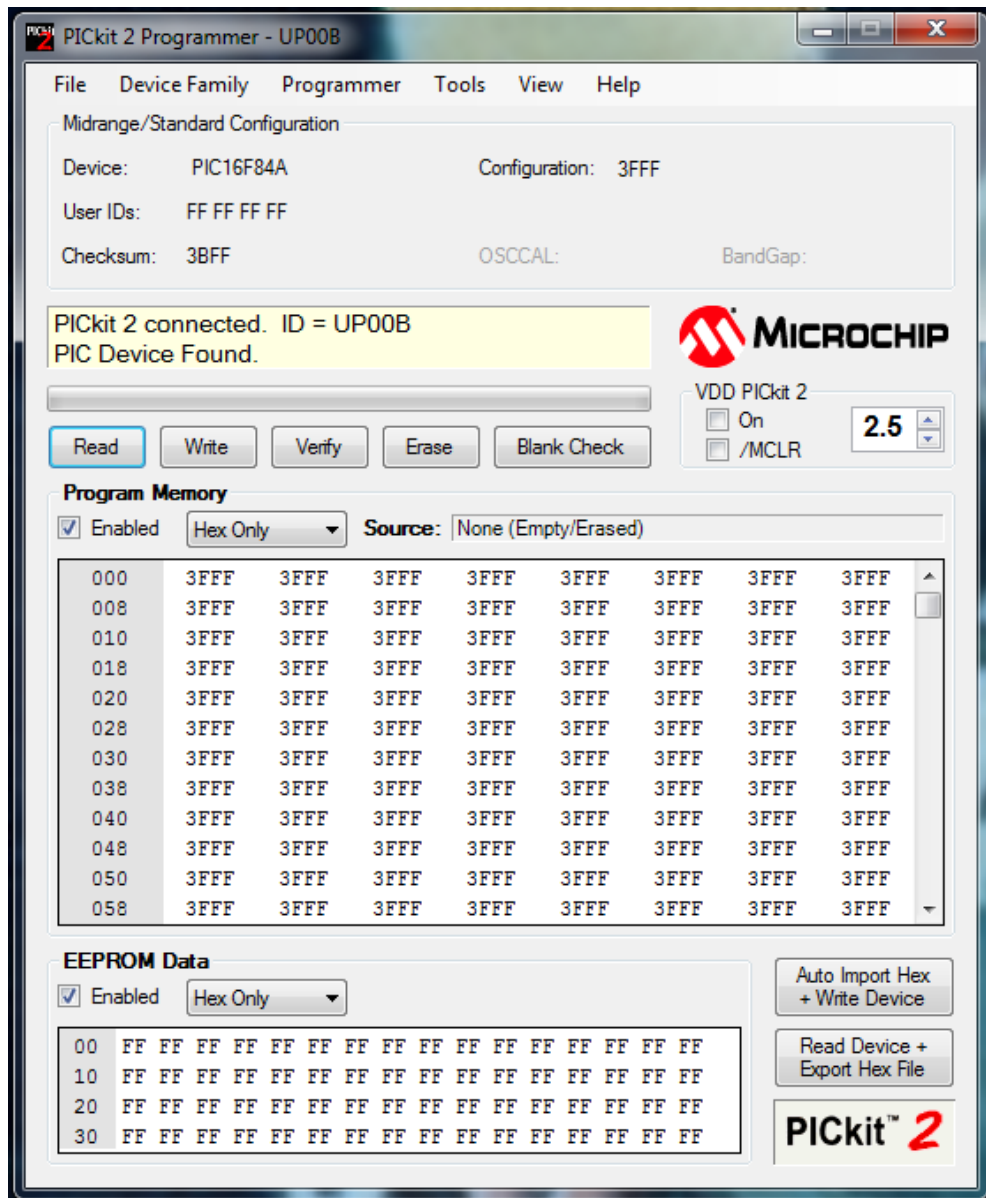
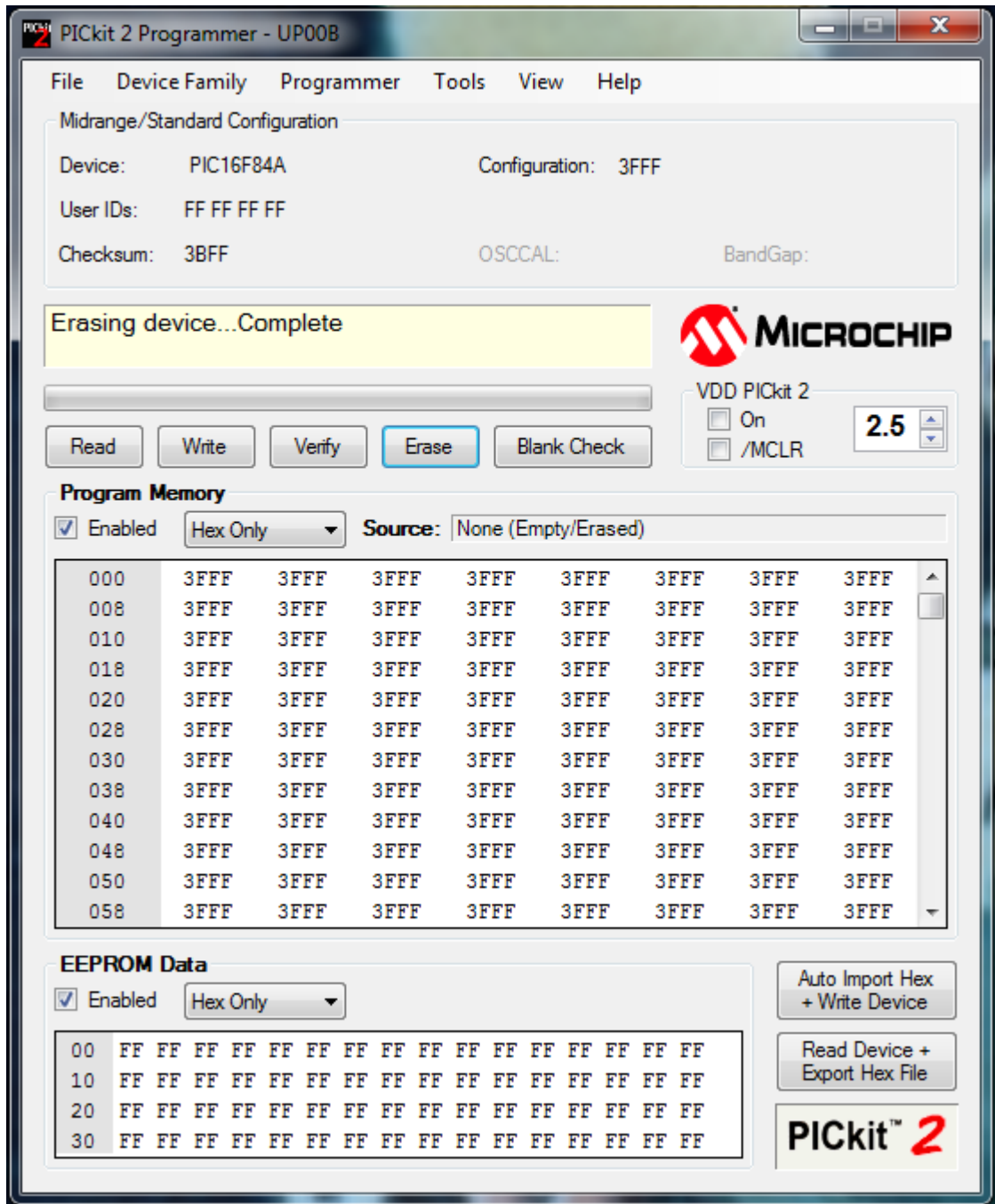
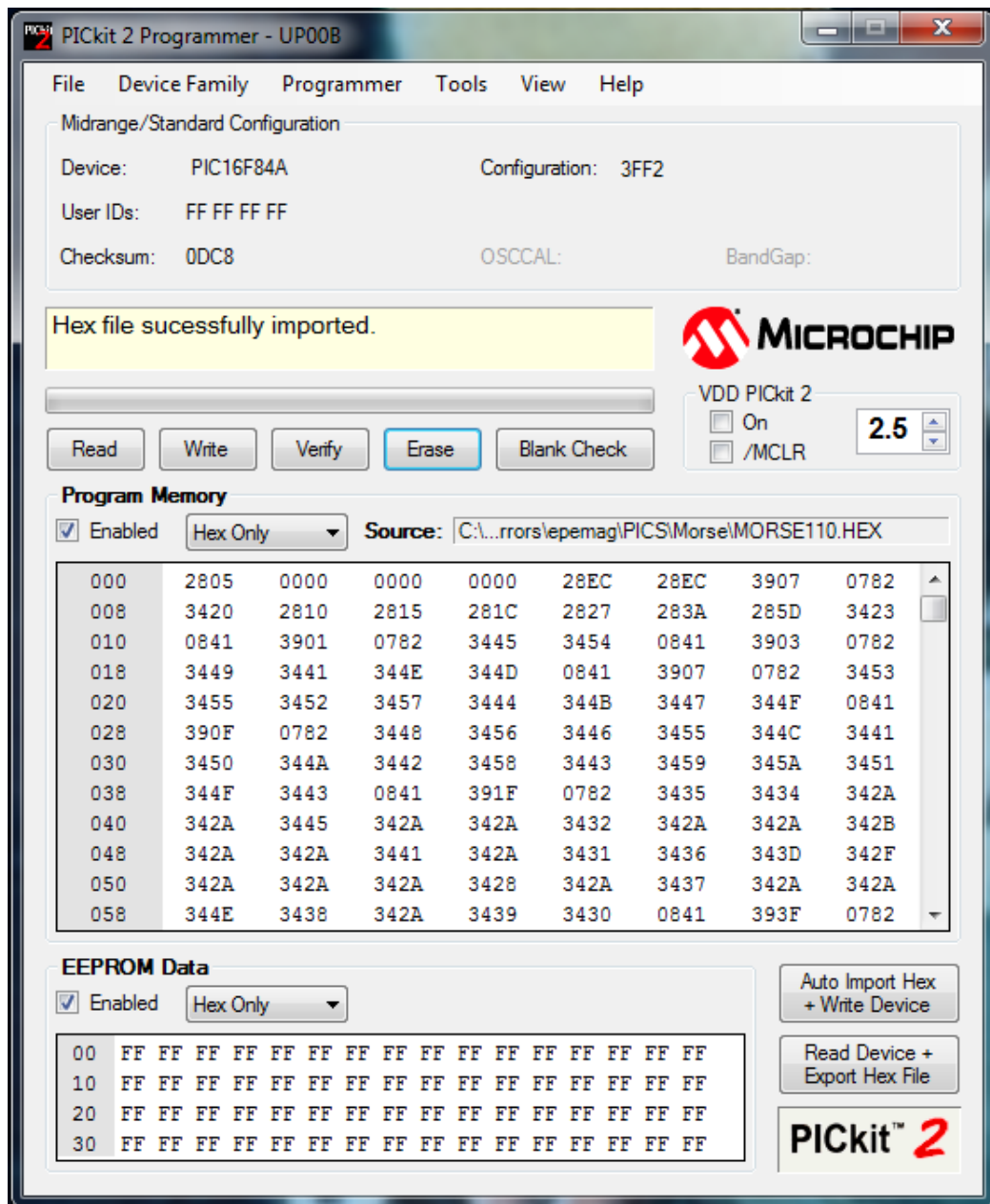

Figure 3.17 :Read the PIC program process



**Figure3.18** :Erasing program process

Firstly : Figure 3.17 and Figure 3.18 is the process,read and erase the program that already inside the PIC . This process have to do it before we install a new program .



**Figure3.19** :Program that install into PIC16F84

Secondly : Figure 3.19is the step the HEX file is import .

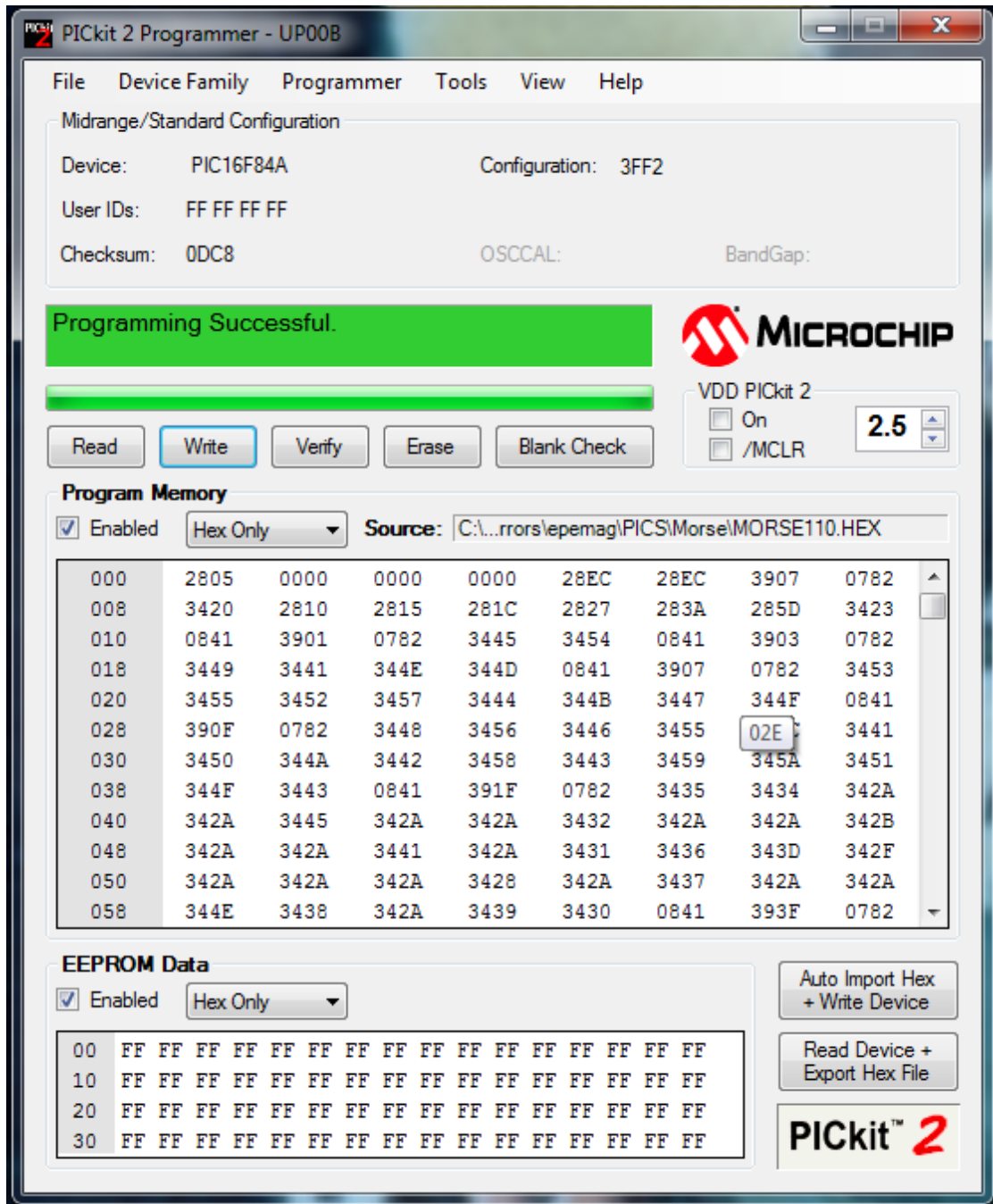
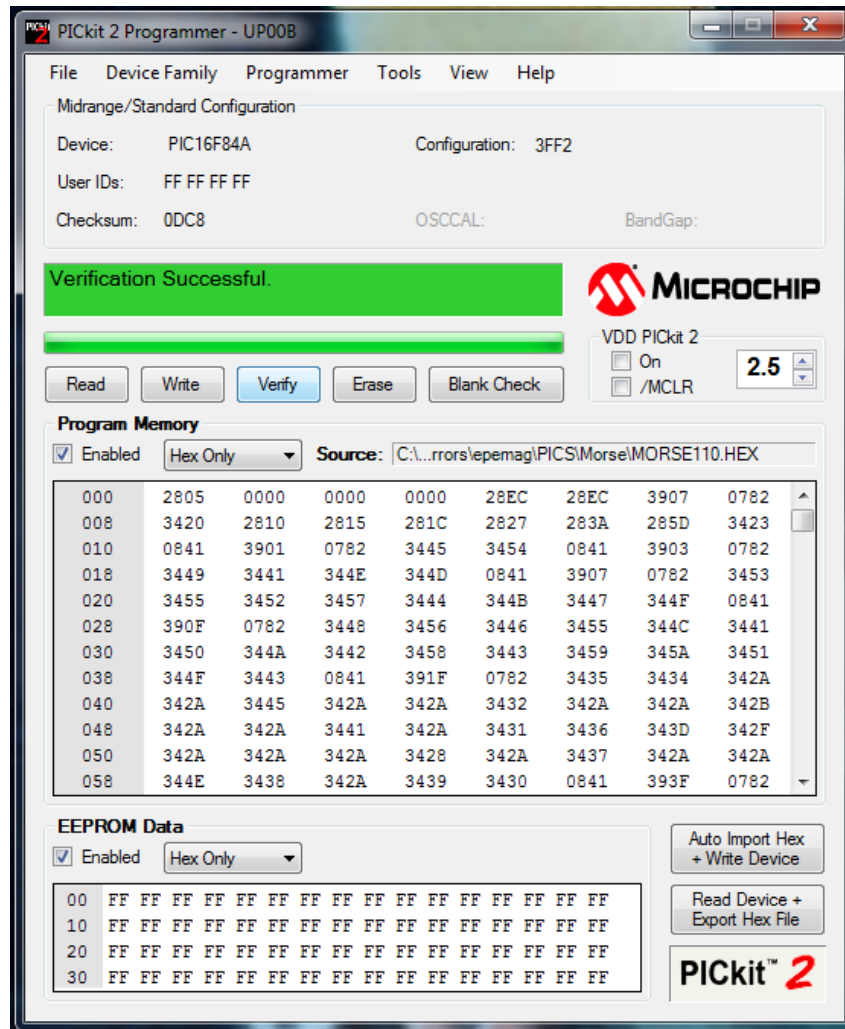

Figure3.20 :Writing programming process



**Figure 3.21** :Verification process

Thirdly : Figure 3.20 and Diagram 3.21 is the step that the hex file is been program into the PIC and be verify .

The diagram 3.17- 3.21 shows the is the steps that the PIC is been program with the encoded system . We program using PICKits.

### **3.6 SUMMARY**

The time thinking reaction time tester have its own requirement to be created successfully by the follower. By follow and studying the requirement of the projects, construction, block diagram and the instruction of the project, the project will successfully function . Some of the construction circuit sometimes failed to function due to usage input and output of the circuit. The hardware and the software need to be done carefully to make sure the project are in the progress.

## **CHAPTER 4**

### **RESULT AND ANALYSIS**

#### **4.1 INTRODUCTION**

From the literature review, circuit details and the construction of this project “Morse Code Reader” the result of this project is positive related to the sound input( Morse code trainer ). This morse code trainer helps people to be more appreciate about the old secret message .The results as the figure 4.1 below. From that this project appear as the one solution of to read or understand about morse code to the user. From the literature review of this project it make us more understanding about the hardware and the software of this project. From the construction the input and the output is positive. The input of this project circuit is need to be modify . And the output of this project only can get if the software of the project is available to the microcontroller that we use. Example of the output and the input are the number displayed at the LCD. The result of



this project will get by follow the final steps of this project .The final steps are the instruction of use this morse code trainer.

By build this Morse code Trainer, we also can learn to use a morse code trainer but a click a button , encourage them to be more understand about this morse code sound. Besides that this opportunity of this project is for the student that taking military. This is the simplest project for government and the student to learn something new with the old stuff .

## 4.2 RESULT

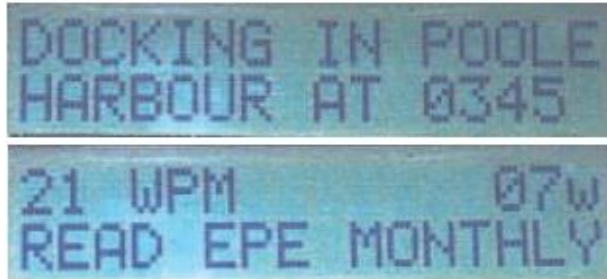
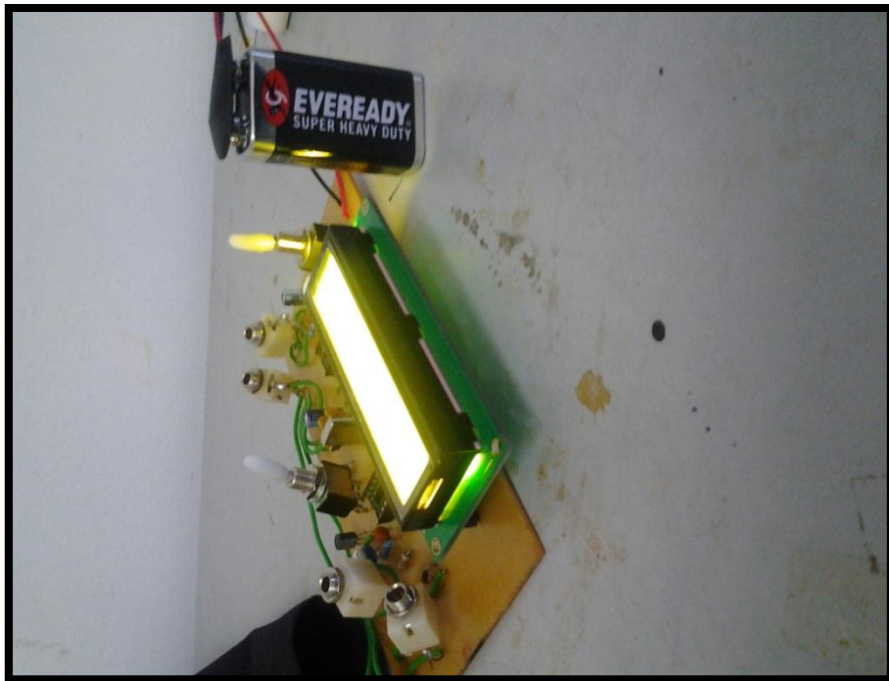

**Figure 4.0 :** LCD screen in 2-line

Before we get the successful result , we get some problem with the circuit . First result unsuccessful like figure 4.2 and 4.3 .this circuit is the circuit that we build our own . Second result is successful but at the presentation day , our project have some problem . The project is not function the way it should be , its maybe occur because of the microphone and maybe occur because the area . This project have some weakness like can detect the sound caused by noisy , the result in the figure 4.4 and figure 4.5 .



**Figure 4.1 :** Testing the circuit



**Figure 4.2 :** Using 9V battery as a source

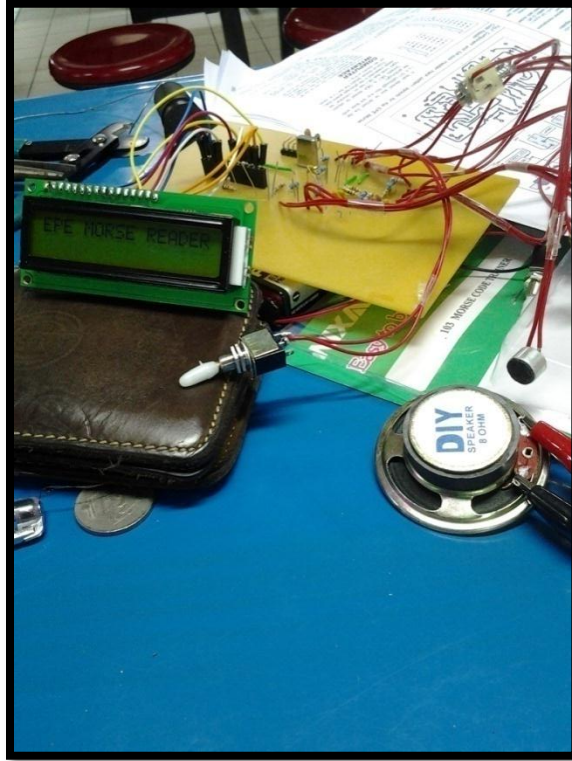

**Figure 4.3** :Troubleshoot process



**Figure 4.4** : Result

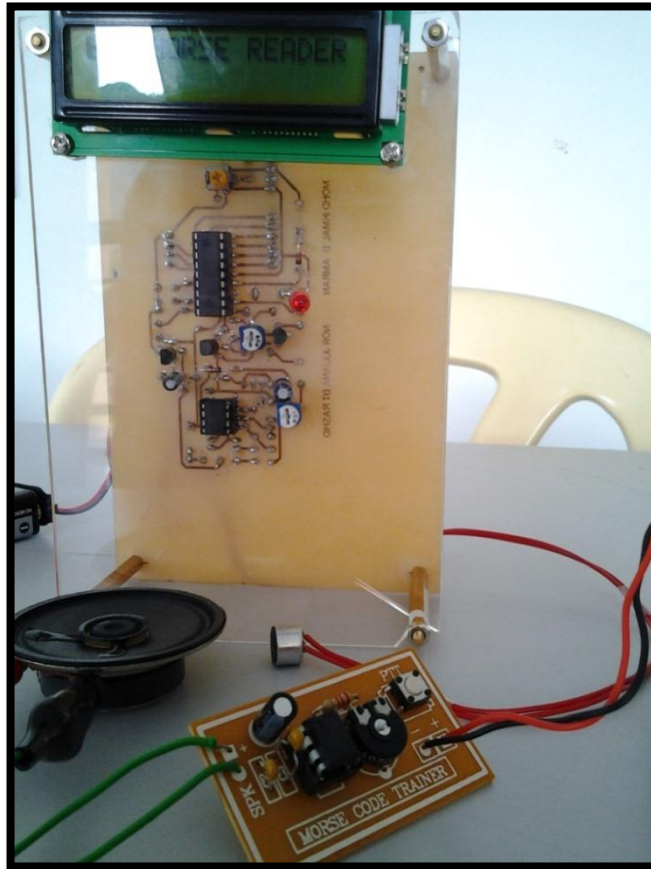

**Figure 4.5 :**Morse code reader and Morse code trainer

### **4.3 SUMMARY**

The positive reaction during driving give a big impact on decreasing an accident and human thinking to be more concentrate in any situation. Time thinking reaction are the most simplest driver product that focusing on mind thinking people. The faster reaction time of this driver alert tester it is the best way for driver alert in their driving life. From that the driver will know their standard during driving depends on their percentage that appear on 7-segment. This progress is the best progress for mind thinking and it also help driver to be more prudent and more motivation.

## **CHAPTER 5**

### **RECOMMENDATION AND CONCLUSION**

#### **5.1 RECOMMENDATION**

In this project, the last result is failure it may be caused by the noise from outside. In the future, use AFSK (audio frequency shift-keying) by sending Morse code audio to the project from the computer's sound. The signals generated by computer have sine waveform and a smooth envelope, so no annoying key clicks. The rise and decay times of the Morse code signals are automatically adjusted to the sending speed, so a minimum bandwidth is occupied, especially for QRS (slow sending). So with this solution the signal is less interrupted by noise, so that the message is easy to receive by the microphone (sensor). Double the frequency resolution, display of incoming signals is more sharp to much less side lobes visible and double the time resolution to length of short dots is displayed more accurately.

## **5.2 CONCLUSION**

The conclusion of this Morse code Reader, it is the simplest product that focusing on the military to understand the morse code. Nowadays we know that this morse code is not really use by everyone because of all the technology nowadays. As a result this Morse code reader technology with programmed, help the military to know the morse code in easy way to understand. This will give a big impact to the government and the military to be more understand the morse code. This manual tester is amazing because it will detect the sound of the dots and dashes this product is related to the objective that to build a morse code trainer is because from the morse code trainer that will create sound morse code by the user ..The sound will be detect by the microphone( sensor ) that will appear at the LCD.The heart of this system is the PIC, the PIC is programmed well by the decoded the sound to relate with the circuit progression.

## **5.3 SUMMARY**

This Morse code Reader project is to create a easy way to understand morse code. To encourage people to learn about morse code. The LCD as the output .this project is something that really interesting to do and learn .

This project is something that really interesting to do and learn . So this project is suitable for all kind of age, student,military ,and the policeman.

In doing this project has achieved many goals such as to study on the project to identify the morse code. We do a lot of projects to increase knowledge



in technical areas such as circuit design of the first step etching PCB board, drill and install the microcontroller that function as the hearth of the system. Program the IC gives us new skills in learning microcontrollers characteristic and we can also learn ways to test if the circuit and component construction that need to be modified as the IC accept the voltage supplies. The most knowledge we get is on programming and the designing of modification the circuit. This project also shows a great future development in electrical building system.